

Underwater Broadband DC-PLC Sensor Networks

Vladimir Burstein^(1,2) and Werner Henkel⁽²⁾

⁽¹⁾ATLAS ELEKTRONIK GmbH, Bremen, e-mail: vladimir.burstein@atlas-elektronik.com

⁽²⁾Transmission Systems Group (TrSyS), Jacobs University Bremen, e-mail: werner.henkel@ieee.org

Abstract

This contribution identifies and summarizes the challenges and major system design decisions in the development of a broadband PLC sensor network, with DC power supplies and sensors as well as connecting cables, located in a harsh environment. Using an underwater sonar network as an example, the physical layer parameters and system design are discussed. A prototype of the new Multi-Carrier Twisted-Pair Bus (MC-TP) transmission system is then introduced.

Index Terms

DC-PLC, bus systems, sensor networks, sonar data transmission, DMT, TEQ

I. INTRODUCTION

Power Line Communications (PLC) belongs to the quite successful and widely used transmission technologies, especially in smart-grid applications. The basic idea behind it is to use the AC power wiring as a medium for data transmission. Such a channel, being not optimized for communication purposes, is quite challenging, taking into account time-dependent impedances and numerous impulse noise sources. On the one hand, narrow-band low data rate PLC systems [3] seem to be more appropriate for this kind of a channel. On the other hand, also high-speed systems are commercially available (e.g. Homeplug AV, IEEE 1901, G.9960 [2]).

The other branch of possible PLC applications over DC wiring include studies for on-board control networks on aircrafts [4], ground vehicles [5], ships [6], or as part of embedded robotic systems [7].

An alternative use of the PLC principles for a high-throughput sensor network is the development of a new transmission system, taking into account both communication and power distribution purposes. A linear bus structure, using twisted-pair wiring and differential signaling is a suggested choice in this case. An underwater sensor network for sonar applications is one of the possible use cases for such a transmission system: combined requirements of high data rate and minimized cabling, exposed to an aggressive underwater environment with changing pressure and temperature, are difficult to fulfill with current technology.

The major design challenges and choices for such a DC-PLC system are discussed in Section II. Based on this study, a new DC-PLC transmission system – Multi-Carrier Twisted-Pair Bus (MC-TP) – has been developed. It is introduced in Section III.

II. DC-PLC FOR A BROADBAND SENSOR NETWORK

The process of a new transmission system design typically includes a batch of technological decisions, common for any communication system. The following topics summarize these design steps for a broadband DC-PLC system.

Sensor Network Channel

Given the PLC nature of the transmission system it is natural to use a linear bus structure to transmit both data to and from sensors and power to the sensors, connected in parallel. The resulting channel is frequency-selective and will introduce inter-symbol interference, due to the multi-path nature of the linear bus [8]. The impulse response length can be reduced, when bus termination on the far end is used - the reason why every existing bus system is terminated. In a PLC system such a termination results in power loss due to the introduced voltage divider. The solution is either to use an AC-coupled termination or none at all.

The channel can be considered rather static and still quite communication-friendly, compared to a smart grid. Nonetheless, exposing the cabling to a harsh underwater environment results in very slow fading (changes in characteristic impedance and attenuation), as shown in Fig. 1a. The impedances of all bus transceivers can be optimized in this case, such that the multi-path reflections are minimized for all possible pressure states.

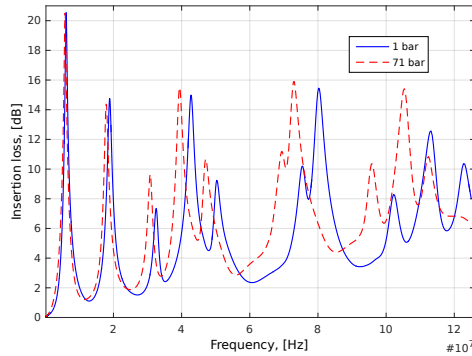

(a) Insertion loss in a bus system with 3 nodes

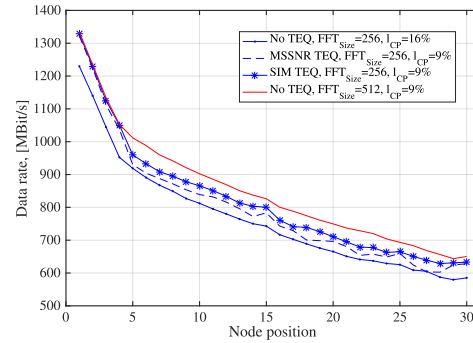

(b) Capacities in a 30-nodes bus system

Channel Sharing Strategy

In the general case of a multi-user multi-access channel (MAC, upstream in a bus system), CDMA can be shown to reach the optimum capacity. Giving users equal priorities results in equivalence of all three multiple access strategies [1]. This is also a typical requirement in a homogeneous sensor network. In practice, TDMA sharing is widely used in bus systems. It is not only the implementation simplicity that speaks for this solution – the passive high-impedance mode of all currently unused transceivers allows the active transceiver to achieve higher data rates due the lower bus load. The simulations show that the higher bus load can hardly be compensated in the FDMA case, when transceivers' output impedances are static and real.

Depending on the application, the downstream channel can be either MAC or broadcast. The sharing in a full duplex mode between the upstream and downstream channels is FDD, which allows to realize two independent channels.

Multi-carrier Modulation

It is an obvious choice to use multi-carrier modulation in the form of baseband DMT – in the frequency-selective channel of a multi-path linear bus. DMT can quite easily be adapted to any channel condition or number of sensors, achieving the high data rate at low implementation cost. In a full duplex system, it can still be a better choice to use a single-carrier modulation for the return channel.

Physical Layer System Parameters

An important part of the transmission system design is the definition of physical layer parameters. The bandwidth in the DC-PLC environment is practically not limited by interference with other systems - using shielded twisted-pair cabling and differential signaling reduces the electro-magnetic emissions to a minimum. The frequency-dependent cable attenuation and its linear dependency on the cable length limits the effective bandwidth to a few hundred MHz for cable lengths around 100 m. The MC-TP uses, for instance, 100 MHz bandwidth - also because of practical considerations like less expensive cabling (Cat5e) and analog front-end hardware.

In case of a multi-carrier system, the lengths of the FFT and the cyclic prefix are essential. The classical way to define these parameters is to estimate the longest possible channel impulse response (in samples), the system has to cope with - then set the cyclic prefix equal to it and the choose the FFT length, such that the cyclic prefix overhead is limited (e.g. 20% at maximum). An optimum approach is to choose a shorter cyclic prefix and tolerate some inter-symbol and inter-carrier interference to get a higher effective data rate due to less overhead [9]. Yet another possibility (various DSL and the MC-TP system choice) is to use a time-domain equalizer (TEQ) [10] that allows to use a very short cyclic prefix and a smaller FFT - this way hardware resources usage can be optimized.

Using a TEQ in Bus Structures

Time-domain equalization is a method used to shorten the effective impulse response and optimize the overall capacity [10]. It is widely used in different wireline applications, like DSL, but less effective in wireless, due to rapidly changing channel conditions.

As stated before, the DC-PLC channel is much more static than a typical PLC, which is the reason behind using a TEQ in the MC-TP system, making it possible to achieve a roughly 10% higher rate. The simulations have shown the possibility

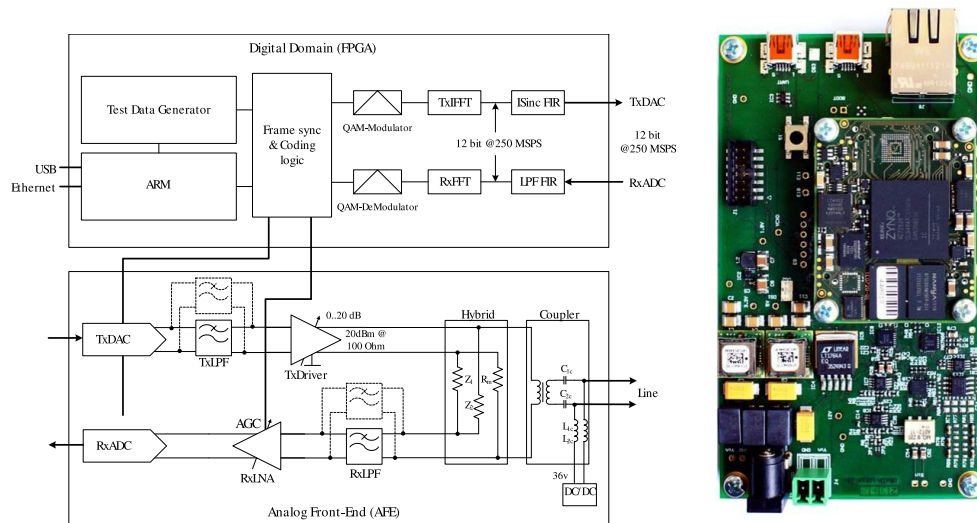

Fig. 2: Transceiver block diagram and prototype

to reduce the FFT size in a TEQ-enabled system (see Fig. 1b), still almost achieving the rate of a system with larger FFT but without TEQ. The important consequence is hardware resources saving, which is especially interesting on the sensor side.

Synchronization Methods

In different scenarios, both blind (using cyclic prefix redundancy [11]) and data-aided methods [12] can be used for symbol and sampling frequency synchronization. The data-aided method with special designed frames is essential for initial or course synchronization, particularly in a system with TEQ – where the cyclic prefix is very short. The blind methods can be used after acquiring initial synchronization, to observe and correct deviations without reducing the effective data rate.

III. MC-TP BUS: A DC-PLC TRANSMISSION SYSTEM

The hardware part of a MC-TP prototype (see Fig. 2) consists of analog and digital front-end. The potential integrated solutions for DSL or PLC applications do not cover the available bandwidth and currently cannot simply be adopted for a DC-PLC application in an optimum way. Thus, the analog part is build of discrete differential elements: low-noise voltage-controlled amplifier and attenuator as an input to a high-speed ADC; high voltage-swing amplifier at the output of a high-speed DAC as cable driver. The reconstruction and anti-aliasing filters are passive – which is more easily possible if oversampling is used. The MC-TP sampling frequency is chosen to be 250 MHz.

The digital part is implemented on an FPGA and includes a multi-carrier parallel QAM (de-)modulator with configurable constellation size, FFT block and FIR filters for implementing TEQs and pre-equalizers ($1/\text{sinc}(x)$).

ACKNOWLEDGMENT

The authors would like to thank ATLAS ELEKTRONIK GmbH in Bremen for sponsoring the project, providing hardware and software support and test facilities.

REFERENCES

- [1] Thomas M. Cover, Joy A. Thomas, *Elements of Information Theory*, Second edition, John Wiley and Sons, 2006
- [2] H.A. Latchman, S. Katar, L. Yonge, S. Gavette, *Homeplug AV and IEEE 1901: A Handbook for PLC Designers and Users*, Wiley, 2013
- [3] Stefano Galli, Thierry Lys, *Next Generation Narrowband (Under 500 kHz) Power Line Communications (PLC) Standards*, China Communications, 2015, pp. 1
- [4] Larhzaoui, T., Nouvel, F., Baudais, J.-Y., Degauque, P., Degardin, V., *OFDM PLC transmission for aircraft flight control system*, International Symposium on Power Line Communications and its Applications (ISPLC), 2014, pp. 220-225
- [5] Yen-Chang Chen, Shang-Ho Tsai, Kai-Jiun Yang, Ping-Fan Ho, Kuo-Feng Tseng, Ho-Shun Chen, *Vehicular signal transmission using power line communications*, Signal Information Processing Association Annual Summit and Conference, 2012, pp. 1-4

- [6] Antoniali, M., Tonello, AM., Lenardon, M., Qualizza, A., *Measurements and analysis of PLC channels in a cruise ship*, International Symposium on Power Line Communications and Its Applications (ISPLC), 2011, pp. 102-107
- [7] Dongsheng Yang, Verl, A., Schmitz, S., Wurst, K. -H., *Implementation of a new communication system for reconfigurable mechatronic modules*, International Asia Conference on Informatics in Control, 2010, pp. 33-36
- [8] Vladimir Burstein and Werner Henkel, *Channel characterization for underwater broadband PLC sensor networks*, International Symposium on Power Line Communications and Its Applications (ISPLC), 2015, pp. 166-171
- [9] A. M. Tonello, S. D'Alessandro and L. Lampe, *Cyclic Prefix Design and Allocation in Bit-Loaded OFDM over Power Line Communication Channels*, IEEE Transactions on Communications, 2010, volume 58, number 11, pp. 3265-3276
- [10] R. K. Martin, K. Vanbleu, Ming Ding, G. Ysebaert, M. Milosevic, B. L. Evans, M. Moonen and C. R. Johnson, *Unification and evaluation of equalization structures and design algorithms for discrete multitone modulation systems*, IEEE Transactions on Signal Processing, 2005, volume 53, number 10, pp. 3880-3894
- [11] Van de Beek, J.-J., Sandell, M. and Borjesson, P.O., *ML estimation of time and frequency offset in OFDM systems*, IEEE Transactions on Signal Processing, 1997, volume 45, number 7, pp. 1800-1805
- [12] Schmidl, T.M. and Cox, D.C., *Robust frequency and timing synchronization for OFDM*, IEEE Transactions on Communications, 1997, volume 45, number 12, pp. 1613-1621